



# ORBEX GROUP

*Revolution in Motion*



## HOW CUSTOM BLDC MOTORS IMPROVE PERFORMANCE & LOWER YOUR COSTS

Engineers often turn to off-the-shelf brushless DC (BLDC) motors as stand-alone components to work into their designs. But oftentimes it makes sense to order a custom motor to meet application requirements out of the reach of commodity motors.

There are two main reasons for considering a custom motor. The first is to improve size and performance. Commodity motors, by definition, are a “take what you get” proposition when it comes to size and performance. Custom BLDC motors and motor assemblies can be designed to fit in tight or irregular spaces without sacrificing torque density. Motors can also be customized for demanding operating environments—whether the threat is thermal, corrosive or electromagnetic.

The second reason is to improve cost. You might think that custom equates to costly. But in many applications, the opposite is true. For example, custom motor assemblies allow feature integration that can ultimately take cost out of your products by reducing the number of components on your bill of materials and assembly time.

This white paper will explore the advantages of custom BLDC motors and also provide several real-world examples of what’s possible.

## Custom Motor Wheel Drives for AGV Applications

One emerging application for BLDC motor customization is automated guided vehicles (AGV), which play an increasingly important role in the factories and warehouses of the future. Because BLDC motors deliver reliable performance across speeds and torque ranges, already they're a good fit for continuously rotating joints in robotic vehicles.

At Orbex, we recently developed two custom BLDC motors for AGV applications. The first incorporates a 2-kilowatt, 120-millimeter frame motor with integral brake and encoder, as well as an optional wheel and tire. This motor integrates a very compact, yet torque-capable roller reducer directly coupled to the motor output. This arrangement not only saves space and cost but also increases driveline stiffness.

The second motor is a similar smaller system based on a 1-kilowatt, 80-millimeter frame motor. It achieves gear ratios as low as 16:1, leading to speeds of 2 meters per second. It also boasts high radial load capabilities for carts with 2,000-pound payloads and incorporates optional case rotation, which centers loads over output bearings to minimize moment loading.

## Custom Through-Hole Table & Motor Configuration for High Loads

In this second application, our engineers configured a custom integrated rotary through-hole table and servo motor to create a complete actuation solution for an inspection process. This application incorporated our THT Series of through-hole tables (*see sidebar*), which combines the advantages of servo motors, cam dividers and direct drive motors to provide high precision and rigidity at a fraction of the cost of similar direct-drive tables.

In this sorting application, parts weighing up to 40 pounds needed to be rotated under a sensor array for inspection. The process required a motion control system that could rotate the parts at 200 rotations per minute (rpm) and incorporate a low-profile design to fit the layout of existing work cells.

To meet these requirements for load, speed and size, we combined our HPM60 200 VAC Servo Motor with our THT85 Through-Hole Table—providing a compact, integrated and cost-effective solution compared to direct drive motors and other rotary indexing tables. This custom configuration not only met the application's 40-pound weight and 200-rpm speed requirements, but it also improved system precision and stiffness compared to more costly direct drive motors.

## BLDC Versus Stepper Motors

Thanks to their high torque and compact size, BLDC motors are becoming a popular choice for today's dynamic servo applications. In many ways, these motors are a "step up" from stepper motors—improving the performance of your servo machines, lowering your maintenance needs and reducing costs.

While stepper motors do have their place—for example, in applications that don't require advanced position control, high shaft speeds or space savings—BLDC motors are the way to go in more demanding applications. These motors pack a lot of torque in a compact package and feature high power output—roughly three times that of equivalent stepper motors. This difference is due to the high number of poles stepper motors need to achieve precise position control and inefficient open loop control techniques. BLDC motors, on the other hand, achieve precision without the tradeoff in rotational speed or torque. They operate at higher speeds and are ideal for applications requiring closed-loop control—from robotic arms to packaging machines.

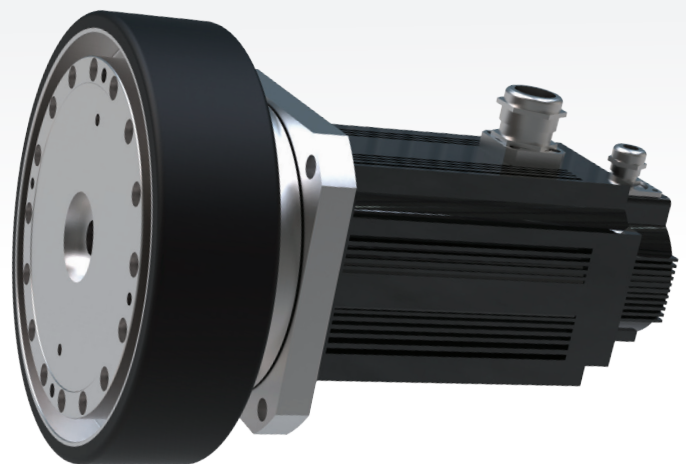

*Custom BLDC motor with integrated gearbox assembly for AGV applications.*

## The THT Series of Through-Hole Tables

Ideal for motion control and automation applications, our THT Series incorporates high transmission efficiency, precision and rigidity in a compact package. The series includes our 62, 85, 130, 200, 300 and 450 models, which feature six frame sizes from 62 to 450 millimeters.

Other notable features include:

- Torques from 5 to 192 Nm
- Servo motors: 10 Kw or 10,000 W
- Speeds to 200 rpm
- Accuracy to  $\leq 10$  arc-sec

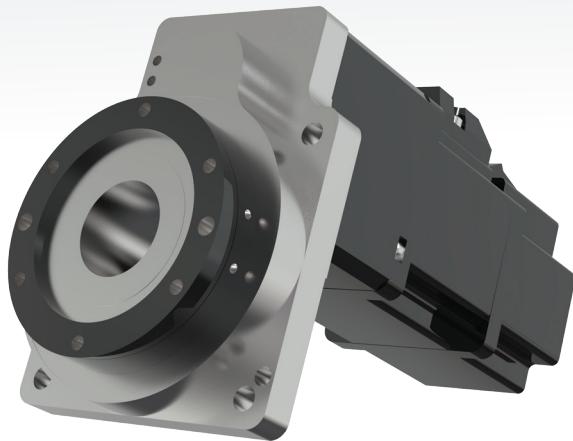

*The THT Series through-hole table.*

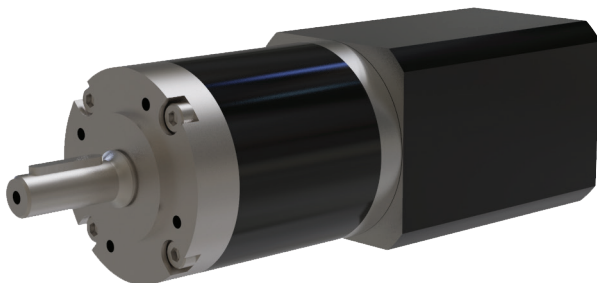

*Custom BLDC motor with integral planetary gear reducer.*

## Custom BLDC Motor with Integral Planetary Gear Reducer

In our third example, we designed a BLDC motor with an integral planetary gear reducer for a motion control application. By optimizing the design of this motor to meet various speed, voltage and mounting requirements, we successfully supplied a high-quality assembly that improved motor controllability and saved costs.

In this application, the OEM required a brushless gear motor solution for a motion control application that met the following requirements:

- Short overall length
- Planetary reducer with a 25:1 gear ratio
- 48 VDC bus voltage
- High-resolution encoder feedback
- Commutation signals
- Greater than 2.5 Nm at 160 rpm

Our engineers tackled this application by modifying our EC4260 BLDC motor with a special shaft, enabling direct mounting to a two-stage planetary reducer. This design eliminated the need for costly adapter plates and internal couplings—saving costs and minimizing length.

In addition, we optimized the motor's winding to meet the required 48 VDC bus voltage. These modifications also allowed the motor to achieve high speeds with minimal current draw. Completing the package, we integrated a 16,384-count magnetic encoder. The added resolution not only provided superior servo control, but also improved controllability and stability.

These modifications successfully eliminated costly adapter plates and prevented component overspecification—resulting in a cost-effective assembly for less than \$200.

## Get Started with Orbex Custom Motors

From packaging to communications, BLDC servo motors are continuing to gain traction in a variety of industries—and for good reason. In addition to achieving high torque, smooth rotation and minimal torque ripple, they lend themselves well to customization in ways that can improve performance and lower your cost.

**To learn more about custom BLDC motors, visit [www.orbexgroup.com](http://www.orbexgroup.com).**