

Proper Use and Mounting Instructions: Through-Bore Slip Ring

1. The through-bore slip ring is designed to be mounted rigidly to the rotating drive rod with the body floating. The slip ring's inner bore should be slightly larger than the diameter of the drive rod for the application. A slip fit over the drive shaft is needed at a minimum. Bushings can be used to match shaft diameters that are in between the standard thru bore diameters.

2. The rotor is secured to the rotating drive shaft that runs through the middle of the slip ring with set screws located on the slip ring's rotor. The anti-rotation tab (See Figure 1 and 2) should be fitted loosely over a stationary dowel to keep the body from rotating. Other than rotation, it should be free to move slightly based on variances in the alignment of the assembly.

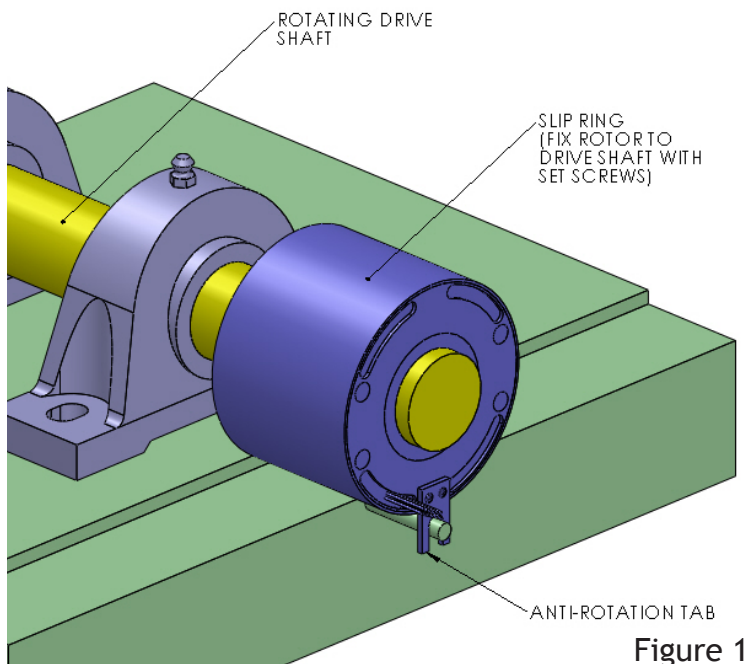

Figure 1

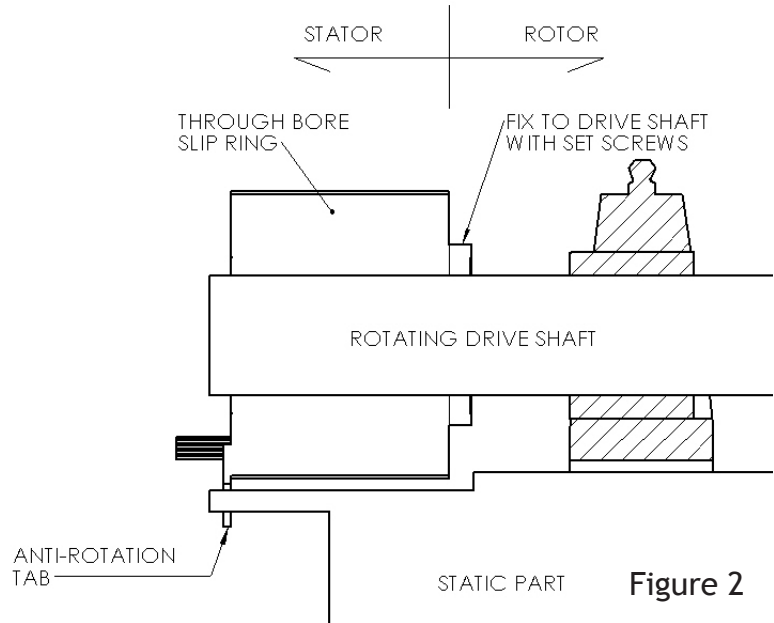

Figure 2

3. The slip ring is NOT designed to bear the weight of the equipment to which it is connected. Rotating equipment should be supported so that axial and radial forces applied to the slip ring bearings are minimized.

4. Because of possible variances, “hard mounting” of both ends of the slip ring (ie. securing the rotor and stator such that there is NO compliance during operation) is not recommended and may cause premature failure.

5. The slip ring should be protected from dust and moisture. If installed in an outdoor application, the slip ring should be designed to operate in a weather-proof enclosure.

6. Secure the leads so that they do not contact any surface of the equipment as it rotates. While routing the wires, do not allow the leads to apply any side loading to the slip ring.